



# River 290

## Small boats , big adventures!

*River Boats have built high quality seaworthy boats in Norway since 1995. An award-winning modular design focusing on high levels of safety, functionality and low cost of ownership.*

*The River 290 is the perfect small allround-boat, suitable for rowing, towing and motorboating. The robust construction and low weight allows for versatile use. With excellent stability combined with heavy duty handles the boat is ready for flexible and safe use. The River 290 can easily be transported on a flat-bed trailer or on the roof of a car or truck..*

*The River 290 is s a practical, inexpensive boat with modern user friendly features, available in a variety of colors, with or without XR steering console kit. River Boats have delivered over 12 000 boats to satisfied customers worldwide for a variety of uses.*



**River Boats**

# River 290

## River Boats - simple boating, safe and affordable!

Our boats are manufactured from environmentally friendly polyethylene, which is extremely impact resistant and durable, as well as requiring minimal maintenance.

River Boats are 100% recyclable and sustainable. The trademark hulls are best described as a hybrid between catamaran and V-hull, providing high levels of stability and handling.



### Recognitions:

Member of Norboat (Norwegian Boat industry Association)



Member of NBL (Norwegian Boatbuilders Association)



We are proud of the Norwegian boatbuilding tradition. DNV-GL approved as an addition to the mandatory CE marking.



River Boats have been awarded the MFGD (Certificate of excellence for -Design) by DOGA, the Norwegian Design Council.



### Technical data

Loa:	2,90 m/9,7 feet	Net weight w/o engine:	~80kg / 176 lb
Beam:	1,50m / 4,9 feet	Max. no. persons:	3
Outboard (short shaft):	max. Engine effect 7,3kW /9,9hp	Max. load capacity:	260kg / 573lb
Engine power range:	4 – 9,9hp	Design category:	D
V-hull angle (hybrid catamaran)	14°	Self bailing and double hulled	

Integrated tow- and davit fixtures

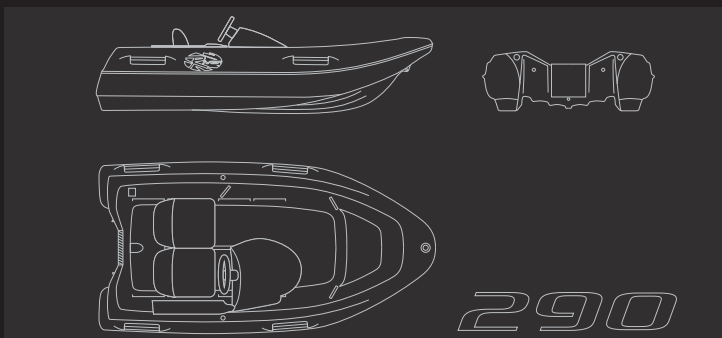

Dealer stamp area:

### XR-kit

The XR-kit consists of the steering console, complete steering system, USB charger, two seats and a channel for cables. The holes for the oarlocks are plugged and a paddle is included for safety.

Please follow us on social media



# River Boats

www.riverboats.no

SUSTAINABLE NORWEGIAN BOATING





*\*Chartplotter, targa frame, rails and lantern are optional extras.*

# River 350

## **Small boats, big adventures!**

*River Boats have built high quality seaworthy boats in Norway since 1995. An award-winning modular design focusing on high levels of safety, functionality and low cost of ownership.*

*The River 350 combines an easily planed, fast hull with extreme stability, resulting in market-leading performance. The specially designed hull is best described as a hybrid v-hull catamaran. With Design Category C-certification the River 350 is unique in its class, confirming the robustness and capacity. Availability in several special models and optional extra equipment allows for customization and tailoring to suit every need.*

*The River 350 is a practical inexpensive boat with modern user friendly features and is available in a variety of colors, with or without XR steering console kit. River Boats have delivered over 12 000 boats to satisfied customers worldwide for a variety of uses.*



**River Boats**

[www.riverboats.no](http://www.riverboats.no)

# River 350

## River Boats - simple boating, safe and affordable!

Our boats are manufactured from environmentally friendly polyethylene, which is extremely impact resistant and durable, as well as requiring minimal maintenance.

River Boats are 100% recyclable and sustainable. The trademark hulls are best described as a hybrid between catamaran and V-hull, providing high levels of stability and handling.



### Recognitions:

Member of Norboat (Norwegian Boat industry Association)



Member of NBL (Norwegian Boatbuilders Association)



We are proud of the Norwegian boatbuilding tradition. DNV-GL approved as an addition to the mandatory CE marking.



River Boats have been awarded the MFGD (Certificate of excellence for -Design) by DOGA, the Norwegian Design Council.



### Technical data

Loa:	3,50 m/11,7 feet	Weight w/o engine:	~110kg / 242lb
Beam:	1,50m/4,9 feet	Max. no persons:	3
Outboard (short shaft):	max. engine power 11kW/15hp	Max. load capacity:	260kg / 573lb
Engine power range:	5 – 15hp	Design category:	C
V-hull angle (hybrid catamaran):	14°	Self bailing and double hulled	

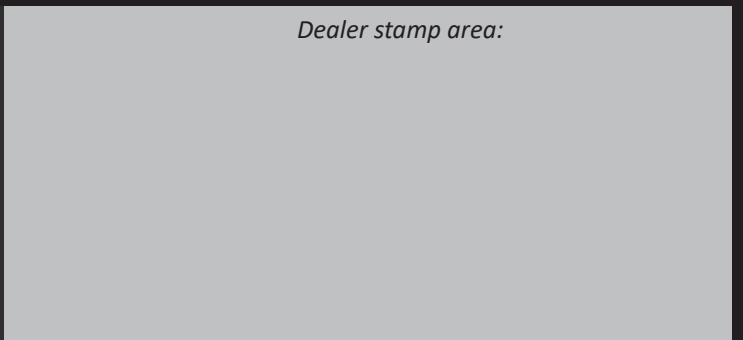
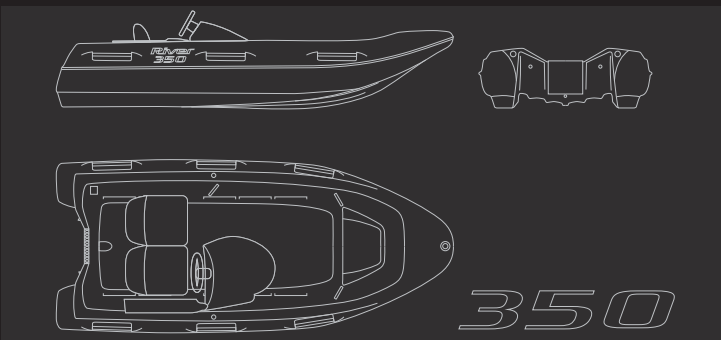

### XR-kit

The XR-kit consists of the steering console, complete steering system, USB charger, two seats and a channel for cables. The holes for the oarlocks are plugged and a paddle is included for safety.

Please follow us on social media:



River Boats

SUSTAINABLE NORWEGIAN BOATING

www.riverboats.no





*\*The targa frame, rails and lantern are optional extras*

# River 350 Jockey

## **Small boats, big adventures!**

*River Boats have built high quality seaworthy boats in Norway since 1995. An award-winning modular design focusing on high levels of safety, functionality and low cost of ownership.*

*The River 350 combines an easily planed, fast hull with extreme stability, resulting in market-leading performance. The specially designed hull is best described as a hybrid v-hull catamaran. With Design Category C-certification the River 350 is unique in its class, confirming the robustness and capacity. Availability in several special models and optional extra equipment allows for customization and tailoring to suit every need.*

*The River 350 is a practical inexpensive boat with modern user friendly features and is available in a variety of colors, with or without XR steering console kit. River Boats have delivered over 12 000 boats to satisfied customers worldwide for a variety of uses.*



**River Boats**

# River Jockey 350

## River Boats - simple boating, safe and affordable!

Our boats are manufactured from environmentally friendly polyethylene, which is extremely impact resistant and durable, as well as requiring minimal maintenance.

River Boats are 100% recyclable and sustainable. The trademark hulls are best described as a hybrid between catamaran and V-hull, providing high levels of stability and handling.



### Recognitions:

Member of Norboat (Norwegian Boat industry Association)



Member of NBL (Norwegian Boatbuilders Association)



We are proud of the Norwegian boatbuilding tradition. DNV-GL approved as an addition to the mandatory CE marking.



River Boats have been awarded the MFGD (Certificate of excellence for -Design) by DOGA, the Norwegian Design Council.



### Technical data

Loa:	3,50 m/11,7 feet	Weight w/o engine:	~110kg / 242lb
Beam:	1,50m/4,9 feet	Max. no persons:	3
Outboard (short shaft):	max. engine power 11kW/15hp	Max. load capacity:	260kg / 573lb
Engine power range:	5 – 15hp	Design category:	C
V-hull angle (hybrid catamaran):	14°	Self bailing and double hulled	

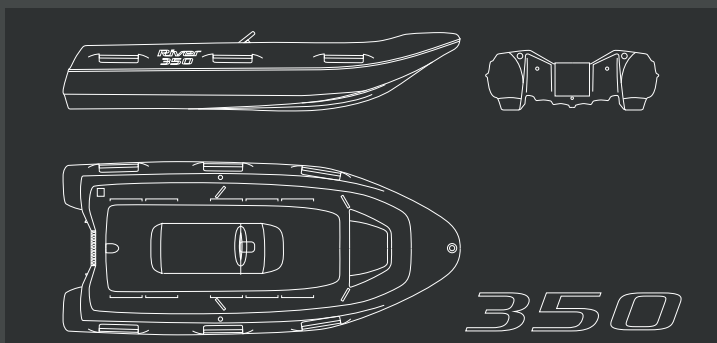

### XR-kit

The XR-kit consists of the steering console, complete steering system, USB charger, two seats and a channel for cables. The holes for the oarlocks are plugged and a paddle is included for safety.

Please follow us on social media:



River Boats

SUSTAINABLE NORWEGIAN BOATING

www.riverboats.no





*\*The targa frame and lantern are optional extras*

# River 420

## **Small boats , big adventures!**

*River Boats have built high quality seaworthy boats in Norway since 1995. An award-winning modular design focusing on high levels of safety, functionality and low cost of ownership.*

*The River 420 is the perfect overall boat for the entire family. The boats unique qualities makes it stable, sporty, easy and fun to drive for youngsters, while also spacious enough to fit a family of 5. The boat is robust and steady, perfect for active use in any weather or season.*

*The River 420 is s a practical inexpensive boat with modern user friendly features and is available in a variety of colors, with or without XR steering console kit. River Boats have delivered over 12 000 boats to satisfied customers worldwide for a variety of uses.*



**River Boats**



# River 420

## River Boats - simple boating, safe and affordable!

Our boats are manufactured from environmentally friendly polyethylene, which is extremely impact resistant and durable, as well as requiring minimal maintenance.

River Boats are 100% recyclable and sustainable. The trademark hulls are best described as a hybrid between catamaran and V-hull, providing high levels of stability and handling.



### Recognitions:

Member of Norboat (Norwegian Boat industry Association)



Member of NBL (Norwegian Boatbuilders Association)



We are proud of the Norwegian boatbuilding tradition. DNV-GL approved as an addition to the mandatory CE marking.



River Boats have been awarded the MFGD (Certificate of excellence for -Design) by DOGA, the Norwegian Design Council.



### Technical data

Loa:	4,20 m/13,8 fet	Net weight w/o engine: ~180kg / 396lb
Beam:	1,80m / 6,9 feet	Max. no persons: 5
Outboard (long shaft):	kW 22,4/30hp	Max. load capacity: 560kg / 1234lb
Engine power range:	10 – 30hp	Design category: C
V-hull angle (hybrid catamaran):	17°	Self bailing and double hulled

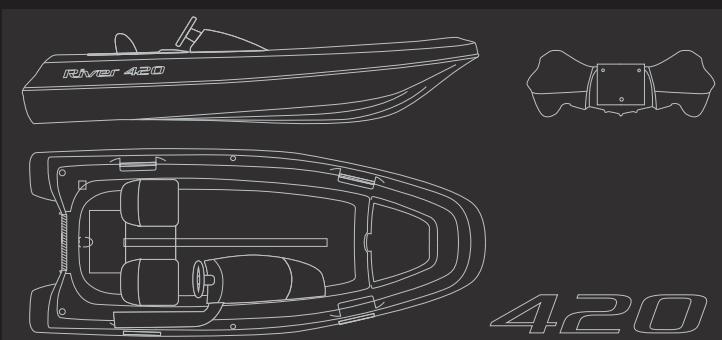

Dealer stamp area:

### XR-kit

The XR-kit consists of the steering console, complete steering system, USB charger, two seats and a channel for cables. The holes for the oarlocks are plugged and a paddle is included.

Please follow us on social media:



# River Boats

SUSTAINABLE  
NORWEGIAN BOATING

www.riverboats.no





*\*The targa frame and lantern are optional extras*

# *River Fish*

*Ocean sustainable*



## **Small boats , big adventures!**

*River Boats have built high quality seaworthy boats in Norway since 1995. An award-winning modular design focusing on high levels of safety, functionality and low cost of ownership.*

*The River 420 is the perfect overall boat for the entire family. The boats unique qualities makes it stable, sporty, easy and fun to drive for youngsters, while also spacious enough to fit a family of 5. The boat is robust and steady, perfect for active use in any weather or season.*

*The River 420 is s a practical inexpensive boat with modern user friendly features and is available in a variety of colors, with or without XR steering console kit. River Boats have delivered over 12 000 boats to satisfied customers worldwide for a variety of uses.*



**River Boats**



# River Fish

Ocean sustainable



## River Boats - simple boating, safe and affordable!

Our boats are manufactured from environmentally friendly polyethylene, which is extremely impact resistant and durable, as well as requiring minimal maintenance.

River Boats are 100% recyclable and sustainable. The trademark hulls are best described as a hybrid between catamaran and V-hull, providing high levels of stability and handling.



### Recognitions:

Member of Norboat (Norwegian Boat industry Association)



Member of NBL (Norwegian Boatbuilders Association)



We are proud of the Norwegian boatbuilding tradition. DNV-GL approved as an addition to the mandatory CE marking.



River Boats have been awarded the MFGD (Certificate of excellence for -Design) by DOGA, the Norwegian Design Council.



### Technical data

Loa:	4,20 m/13,8 fet	Net weight w/o engine: ~180kg / 396lb
Beam:	1,80m / 6,9 feet	Max. no persons: 5
Outboard (long shaft):	kW 22,4/30hp	Max. load capacity: 560kg / 1234lb
Engine power range:	10 – 30hp	Design category: C
V-hull angle (hybrid catamaran):	17°	Self bailing and double hulled

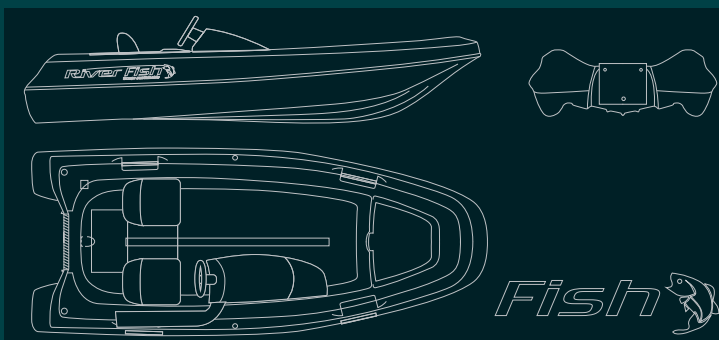

Dealer stamp area:

### XR-kit

The XR-kit consists of the steering console, complete steering system, USB charger, two seats and a channel for cables. The holes for the oarlocks are plugged and a paddle is included.

Please follow us on social media:



# River Boats

www.riverboats.no

SUSTAINABLE NORWEGIAN BOATING

Art & Graphics by REC Consultant

Everything presented in this brochure is subject to change without prior notice

Rotostop as  
Manufacturer of River Boats





# River 460

## **Small boats, big adventures!**

*River Boats have built high quality seaworthy boats in Norway since 1995.*

*The modern modular design is focusing on high levels of safety, functionality and low cost of ownership. River Boats have delivered over 12 000 boats to satisfied customers worldwide for a variety of uses.*

*The River 460 is s a modern, practical multi purpose boat for the entire family, or for professional use for all seasons.*

*The River 460 is available with or without XR steering console set incorporating a windscreen.*



**River Boats**

# River 460

## River Boats, enkelt båtliv til en fordelaktig pris!

River 460 is manufactured in 3-layer sandwich polyethylene, which is extremely impact resistant and durable, as well as requiring minimal maintenance.

River Boats are 100% recyclable and sustainable. River 460 is easy to manoeuvre and has a significantly lower weight than its competitors. Low weight has positive effects such as higher speed and reduced fuel consumption.



### Recognitions

We are proud members of Norboat  
(Norwegian Boat industry Association)



Members of NBL  
(Norwegian Boatbuilding Association)



All stability and sea trials are performed by IMCI  
(International Marine Certification Institute)



River 460 is manufactured following the strictest standards and comply with ISO 9001 og ISO 14001 by Roto d.o.o.



### Technical data

Loa:	4,60 m / 15 feet	Net weight w/o engine: ~210kg / 463 lb
Beam:	1,80m / 6,9 feet	Max. no person: 4/5
Outboard (Long shaft):	max. engine power kW 29,8/40hp	Max. load capacity: 582kg/1283lb
Engine power range:	10 – 30hp	Design category C/D
V-hull angle:	15°	Self bailing, 3-layer sandwich double hull

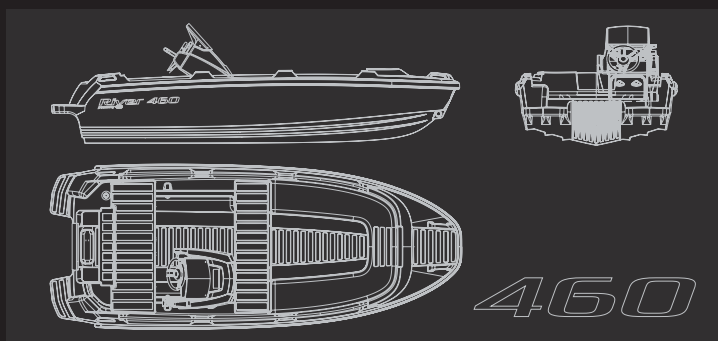
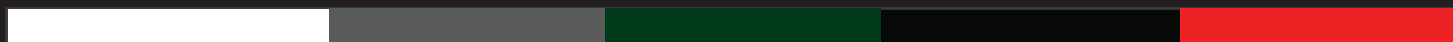

### XR-kit

The XR-kit consists of the steering console, complete steering system and a tinted windscreen.

Dealer stamp area:

Please follow us on social media:



# River Boats

SUSTAINABLE  
NORWEGIAN BOATING

www.riverboats.no





*\*The targa frame, swim ladder and lantern are optional extras*

# *River 460 CC*

## ***Small boats, big adventures!***

*River Boats have built high quality seaworthy boats in Norway since 1995.*

*The modern modular design is focusing on high levels of safety, functionality and low cost of ownership. River Boats have delivered over 12 000 boats to satisfied customers worldwide for a variety of uses.*

*The River 460 is s a modern, practical multi purpose boat for the entire family, or for professional use for all seasons.*

*The River 460 is available with or without XR steering console set incorporating a windscreen.*



***River Boats***

**SUSTAINABLE  
NORWEGIAN BOATING**

[www.riverboats.no](http://www.riverboats.no)



# River 460 cc

## River Boats, enkelt båtliv til en fordelaktig pris!

River 460 is manufactured in 3-layer sandwich polyethylene, which is extremely impact resistant and durable, as well as requiring minimal maintenance.

River Boats are 100% recyclable and sustainable. River 460 is easy to manoeuvre and has a significantly lower weight than its competitors. Low weight has positive effects such as higher speed and reduced fuel consumption.



### Recognitions

We are proud members of Norboat  
(Norwegian Boat industry Association)



Members of NBL  
(Norwegian Boatbuilding Association)



All stability and sea trials are performed by IMCI  
(International Marine Certification Institute)



River 460 is manufactured following the strictest standards and comply with ISO 9001 og ISO 14001 by Roto d.o.o.



### Technical data

Loa:	4,60 m / 15 feet	Net weight w/o engine: ~210kg / 463 lb
Beam:	1,80m / 6,9 feet	Max. no person: 4/5
Outboard (Long shaft):	max. engine power kW 29,8/40hp	Max. load capacity: 582kg/1283lb
Engine power range:	10 – 30hp	Design category C/D
V-hull angle:	15°	Self bailing, 3-layer sandwich double hull

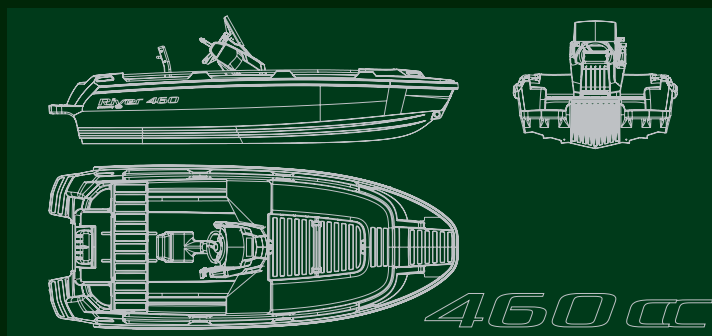

\*The sundeck box as shown in the drawing is an optional extra.

### XR-kit

The XR-kit consists of the steering console, complete steering system and a tinted windscreen



Dealer stamp area:

Please follow us on social media:







*\*The targa frame and lantern are optional extras*

# River Pro

*Custom boat works*

## **Robust boats with minimum maintenance**

*River Boats have built high quality seaworthy boats in Norway since 1995. An award-winning modular design focusing on high levels of safety, functionality and low cost of ownership.*

*River Boats are highly suitable for the professional industry. Examples are emergency, safety, fire, carpentry and rental boats etc.*

*The boats are robust and stable, perfect for active use in any weather or season. River Boats have delivered over 12 000 boats to satisfied customers worldwide for a variety of uses.*



**River Boats**



# River Pro

Custom boat works

## River Boats, enkelt båtliv til en fordelaktig pris!

The boats are manufactured in polyethylene, which is extremely impact resistant and durable, as well as requiring minimal maintenance.

River Boats are 100% recyclable and sustainable. River boats are easy to manoeuvre and has a significantly lower weight than its competitors. Low weight has positive effects such as higher speed and reduced fuel consumption.



### Recognitions

We are proud members of Norboat  
(Norwegian Boat industry Association)



Members of NBL  
(Norwegian Boatbuilding Association)



We are proud of the Norwegian boatbuilding tradition. DNV-GL approved as an addition to the mandatory CE marking.



All stability and sea trials are performed by IMCI  
(International Marine Certification Institute)



River Boats have been awarded the MFGD (Certificate of excellence for -Design) by DOGA, the Norwegian Design Council.



## River Pro

Custom boat works

### Customized solutions

The boats can be tailored to fit your specific needs.

Customization is done in our in-house work shop, with support from our own team of skilled engineers.

Dealer stamp area:



### XR-kit

The XR-kit consists of the steering console, complete steering system and a tinted windscreen.

Please follow us on social media:



River Boats

SUSTAINABLE NORWEGIAN BOATING

www.riverboats.no